

ANNUAL POLICING PLAN FOR THE YEAR 2020-21



DISTRICT CHAKWAL

**District Police Officer
Chakwal**



INTRODUCTION

Article 10(4) of the Police Order 2002 envisages formulation of Annual District Policing Plan. The plan shall include objectives of policing, financial resources likely to be available during the year, target and mechanism for achieving those targets. As a statutory requirement, “Annual Policing Plan 2020-21” is supposed to be submitted to the competent authority for its approval. Although, objectives are derived from the overarching vision for the District Police but the financial resources, earmarked by the government for Chakwal in the financial year and constraints thereof have change initiatives in transforming District Police into an efficient and transparent public service provider entity will be more dependent on the behavioral transformation through short courses at Police liens, redesigning human resource management practice and developing standard operating procedure for police processes and professionalism. However, it is necessary to register at the out that reforming police in accordance with the wishes of the citizens of District Chakwal is inescapably a cost intensive effort where huge public money is involved. Sir Robert Peel in his address to the British parliament on Police Reforms in 1907 expressed his views that,

“The quality of policing is directly proportional to the financial aspects policing. It will be difficult to get a good result without paying for it”.

Despite this financial stringency, Chakwal Police is fully cognizant and committed to its pivotal and crucial role in warding off today’s biggest menace namely terrorism in addition to performing other basic functions and duties as enumerated in “Our Policing Plan”. Effective response to this challenge entails that various components of Chakwal Police act in unison and that optimum levels of coordination and synergies be achieved with other relevant entities within and without the District, in the interest of comprehensive approach to law enforcement, we have also been guided by the need to ensure that counter-terrorism role of the Police would not detract from its ability to meet the broader responsibility entrusted to it maintenance of law and order in the District.

District Detail:

Organogram

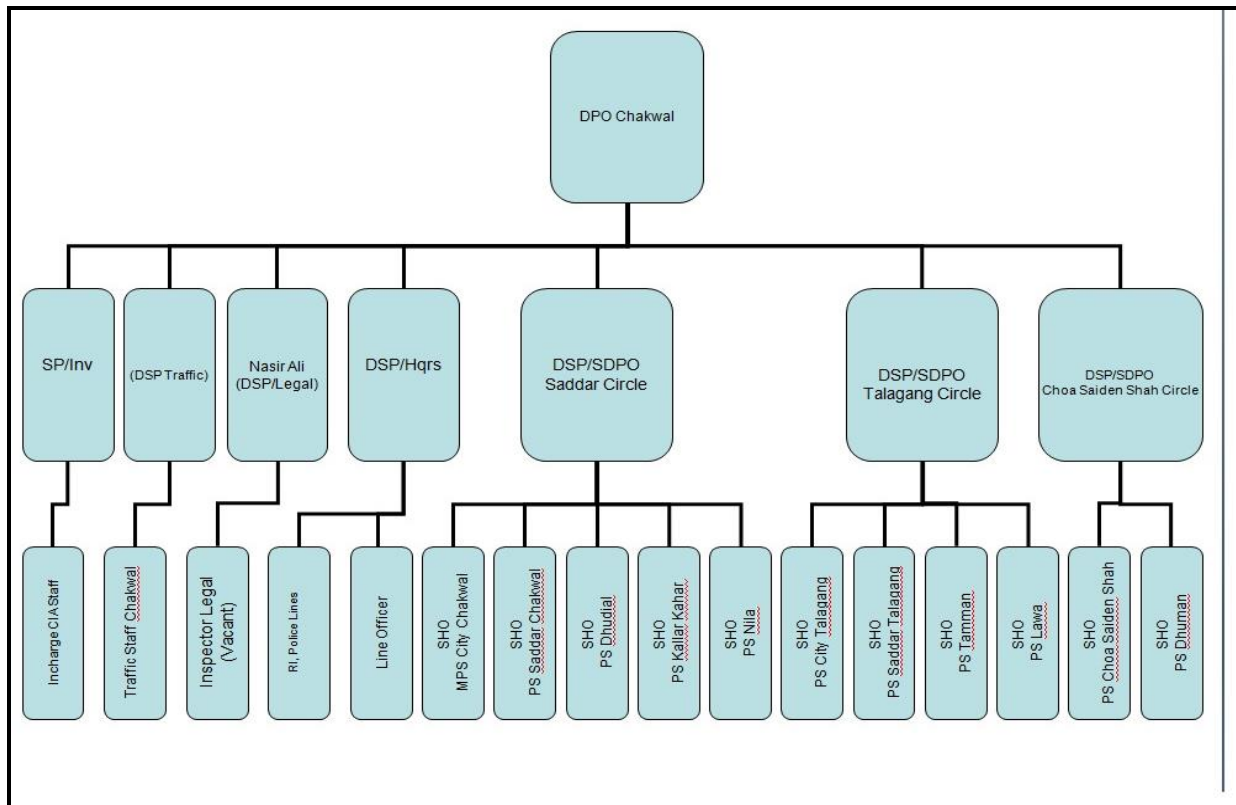

Population:- 1.496 M

Area 6,524 km²

Divisions / Sub-Divisions / Police Station

There are 03 Sub Divisions in District Chakwal i.e. Saddar Circle Chakwal, Choa Saidan Shah Circle, Talagang Circle and 11 Police Station are established in the local jurisdiction of this district. Name of these police stations are as under:-

1. PS City Chakwal
2. PS Saddar Chakwal
3. PS Kallar Kahar
4. PS Dhudial
5. PS Neela
6. PS Choa Saidan Shah
7. PS Dhuman
8. PS City Talagang
9. PS Saddar Talagang
10. PS Lawa
11. PS Tamman

Present Strength

Detail	DPO	SP / Inv	ASP/DSP	DSP Legal	IP Legal	IP	SI	ASI	HC	Const
Sanctioned Strength	01	01	05	02	05	21	52	58	114	1048
Present Strength	01	-	04	01	-	13	45	61	121	979
Shortage strength	-	01	01	01	05	08	07	03	07	69
Excess Strength	-	-	-	-	-	-	-	03	07	-

Logistics (total Nos. of arms & ammo and vehicles

Detail of Vehicles

Toyota Jeep	Bus	Khidmat Mobile	Truck	Prison Van	Carry Van	Pickup Double Cabin	Pickup Single Cabin	Shahzor	Crime Scene Unit Van	Motorcycles
03 on road 04 off road	03	01	01	04	02	04	51	04	01	81

Detail of Arms and Ammo

S#	Detail of weapon	No. of weapon	Ammo
1.	60 MM Martyr Gun	01	59
2.	LMG IA-3	03	4000
3.	Rifle G-3	103	32447
4.	Rifle MP-5	106	9811
5.	Rifle 7.62 MM China	87	12897
6.	Rifle SMG	295	21998
7.	Revolver 38 bore special	90	1685
8.	Brita Pistol 9 MM	90	5229
9.	Rifle 22 bore	15	442
10.	12 bore Pump Action rifle	73	3396
11.	Revolver 455 Bore	20	833
12.	Rifle Muscat 410 bore	46	5022
13.	Rifle 12 bore single barrel	10	-

14.	Brain Gun 303 bore	02	-
15.	Stain gun 9 MM	02	-
16.	Very Light Pistol	04	-
17.	Very Light Pin Pistol	21	25
18.	Rubber Bullet / Rubber Ball	-	7197
19.	Rifle Mar IV 303 bore	514	-
20.	Grenade launcher	20	-

DISTRICT OBJECTIVES OF POLICING

i. Protect Life and liberty of citizen

Our objectives are to fight against the crime and win by providing dynamic and effective law enforcement. The Chakwal Police will strive to uphold core values like integrity, courage, loyalty and fairness in order to promote professionalism and trust. Additionally, we will not be mere protectors of public, we should be guardians of the people and friends to the community and must be a service of tenacious individuals, bounded by a common purpose to serve and go beyond the call of duty. Our motto is based on the principle of 4Ps which says that policing can effectively be measured by purposeful, performance oriented, public centric and punitive action. Transformation of the District Police Chakwal into a service oriented, thoroughly professional, transparent and accountable to general public.

ii. Preserve and promote public peace

With the increase of complexity in the social fabric of Chakwal, maintenance of public order has emerged as a major challenge for police at district level. This year, it is resolved that the issue of maintenance of public order will be dealt with in a scientific and proactive manner. Extensive community – police interaction will be made to keep communities peaceful and law abiding. Interest groups should be identified and marginalized through proactive negotiations. Following guidelines are mandatory to follow;

- Maintenance of public peace and order during public protests, power riots, religious riots etc.
- Regulate processions and public gathering in accordance with Police Order 2002, Criminal procedure Code and Police Rules
- Maintain peace and harmony during Muharram
- Maintenance of peace on national days special occasions

- Work in unison with notables of the area and various pressure groups like Traders and Ulema for maintaining peace and order in accordance with government policy
- Activation of Peace Committees at Police Station level to develop interfaith harmony between the people of different sect
- Metal Detectors – Security measures adopted to guard sensitive Masajid / Imam Bragahs.
- Entry to all special events through Walk Through Gates
- Implementation of SOPs

iii. To improve police efficiency.

Police in Pakistan is undergoing a major credibility crisis. Police should change its behavior and attitude towards the public in order to improve its public image. The world is moving towards the concept of Community Policing at rapid pace; which is policing strategy and philosophy based on the notion that community interaction and support can help control crime and reduces fear of crime.

- Security of tenure of posting / transfers for a fixed one year at least.
- Open Kuchehries are being held regularly at DPO / SDPO office level to attend public complain and address their grievances.
- Rescue 15 and Police Help Centers are functional round the clock
- Close liaison with media to project the soft image of police
- Complaints can be sent via e-mail to the Central Police Office
- Achievements of Police to be publicized
- Meaningful / visible patrolling to restore public confidence and minimize crime
- Preservation of public peace and ensuring safety of the citizen
- Ensuring culture of transparency
- Ensuring fair investigation of cases
- Complaint Cell has been established in the office of the undersigned.
- Zero tolerance against corrupt practices and misuse of authority
- Organization of seminars, workshops and surveys of police image
- Public satisfaction of investigative journalism
- Citizen feedback system
- Help desk of foreigners
- Improving of work ecology at Police Station

TARGETS TO BE ACHIEVED AND MECHANISM

Sr. No.	Category of Targets	Present Status (No. / Percentage)	Expected Achievement of the Target (No. / Ratio / Percentage)	Mechanism
1.	Maintenance of Law & Order	Good	-	Community policing within four corner of law
2.	P.Os	<u>Detail of arrested POs</u> 34 (Cat A) 65% + 185 (Cat B) 70%	<u>Target</u> 80 % (Cat A) 80 % (Cat B)	Through special campaign
3.	Heinous Crime	115 cases 3.59 % of total crime	Decreased upto 70 cases. 2.6 % of total crime	Preventive action / police patrolling mechanism
4.	Capacity Building- Training	90 % of total strength has been completed	Upto 100 %	Courses are being started
5.	Welfare Projects	Copy enclosed Annex – A	-	-
6.	I.T initiatives	Copy enclosed (Annex-B)	-	-
7.	Investigation	Investigation completed in 3084 cases out of 3203 96 %	<u>Target</u> 95 %	Instructions have been circulated through close liaison with prosecution branch
8.	Any other	-	-	-

FINANCIAL RESOURCES LIKELY TO BE AVAILABLE FOR YEAR 2020-21

Code / head of Account	Amount (Total)
Pay and allowances	825166721
POL	50000000
Investigation Cost	1000000
Transport	6500000
Machinery & Equipment	1000000
Furniture & Fixture	600000
Others	3200000

COMMENTS BY DPO

Chakwal Police is facing unprecedented challenges of great severity and magnitude. The major issues being confronted by the District Police Chakwal are combating terrorism, fighting ever more desperate and better equipped criminals and trying to meet the rising expectations of the public. These issues affect the administrative and operational priorities and strategic objects of the police. The Annual Policing Plan 2020-21 circumscribe all these thematic conceptions and makes recommendations based on our social, cultural and capacity of the Police force.

To reinforce our pledge for a balanced force, we have introduced modern concepts of policing as part of the curricula short courses at Police lines in the shape of training strategy. We intend to change the mind set and abysmal state of police cultural at police station level by issuing police guideline like Free Registration cases, Code of Conduct, Guideline of Police Public Relations, Strategy of Kidnapping for Ransom, Strategy to fight Street Crime, Police Commission of Police Encounters to check their veracity and genuineness. Our key performance indicators are based on innovative tools of control encompassing every area of policing. Our major concern is to prevent, restrict and retard the tide of rising crime, abuse of human rights and terrorism.

We intend to transform police into a proactive organization and change its traditional Irish constabulary model to intelligence led policing in which every information is analyzed thoroughly, on the base of statistical data and counter strategies are devised. Therefore, major responsibility for implementation rests with senior police command at district level.

Chakwal Police is committed to be changed into a thoroughly professional, accountable and service oriented department delivering dynamic and effective law enforcement. We promise to continue the struggle to clean our District, of the criminals and terrorist who pose a great threat to the life and property of the general public. We also remember the sacrifices of our Police Officers who offered their lives in order to stem the heinous crime which has blighted our beloved country. In this back drop, we have endeavored to prepare Annual Policing Plan 2020-21, to reset, revise and review our goals, objectives and targets to meet the challenges of the future.

WELFARE PROJECTS

- Financial assistance to the Police Shuhda's families of this district
- Regular monthly financial backing to the widows of late police officers/officials
- Medical financial support to all the personnel including retired officials
- Scholarship for better education
- Provision of Meal to all the force in case of law & order duties
- Purchasing of necessary equipments for temporary security duties
- "Barra Khana" for the force
- Mess is maintained twice a day and standardized food is provided to all police personnel posted at District Police Lines on subsidy basis
- New Air-Condition Police Lines Mess Hall.
- Financial support to the force
- Construction and renovation of police premises
- Accommodation
- Renovation of DPO Office
- Construction of new Police Welfare Canteen
- Police Khidmat Markaz
- Renovation of District Police Lines
- Establishment of Driving School at District Police Lines
- Setup of gymnasium and jogging tracks
- Plantation of flowers in DPO Office & Police Lines officials resident and police stations / police posts.
- Function alongwith Bara Khana and distribution of gift to the Christian employees and their families on the eve of Christmas
- Improvement in laundry/barber shop at District Police Lines
- Establishment of child abused cell
- Orderly rooms were held frequently to listen problems of Police Officials and Police Officials called in OR on daily basis to know their grievances. Grievances of the officials were redressed on the spot.

- Accountability – by deciding of show cause notices and various punishments were awarded to Police Officials on account of negligence and lack of discipline which improved discipline and moral of police force
- Reward for good work done especially against anti-social elements.
- Visited SDPO Offices, police stations, police lines and held formal, informal inspections & Surprise Visits.
- Regular crime meetings
- Establishment of close working relation through forums like Criminal Justice Coordination Committee
- Held Open Kathcehries to attend public complaints during field touring
- Courses to improve Thana Culture & Police behaviour as well as investigation were conducted at Police Lines on regular basis & improvement of Police Image in Public
- Improvement in working of NIU
- Establishment of Resources Management Centre (RMC).
- Mobile Khidmat Markaz is running to facilitate the public at their doorstep.

I.T INITIATIVES

The IT Sector development is such an essential task for the Chakwal Police. Improving efficiency and effective service delivery are part of the objective to help the government's business visions of providing services to the citizens officiously.

E-policing computerization net-working infrastructure and information Technology related projects initiated developed and implemented by the Government of Punjab for Police Department through information Technology Department.

- Copy of FIR
- Vehicle verification
- Tenants Registration
- Employee Verification
- Crime Report
- Loss Report
- E-Courts
- Legal Aid/Women violence
- Employee Registration
- Learner Permit
- Renewal of License
- International License
- Out District Character Certificate
- Out District Renewal of License
- Police Khidmat Counter
- RMC
- PSRMS
- Police Report System
- Crime Mapping
- Hotel Eye
- PMDU
- Character Certificate
- PPDMD
- HRMIS
